

SPECIFICATION SHEET

PRODUCT # GRD562-XX Brass Lilac

Housing: Heavy duty solid Brass construction.

Wiring: 3' #18/2 Direct bury landscape lighting wire with UL listed, Pre-stripped hub-ready leads for quick installation.

Lens: Heat resistant Convex clear Flat Tempered Glass is fully sealed with silicon sealant reduces water build-up and puddle on the lens.

Mounting: 9" In-ground ABS Stake or Surface/ Tree Mounting.

Notes: Operating Frequency: 50 / 60Hz.
Operating Temperature: -4 ~ 122°F (-20 ~ 50°C)
Ambient Temperature: -4 ~ 176°F (-20 ~ 80°C)

Electrical Notes: A remote 12V transformer required, may be ordered to Elram, Inc. separately. Voltage range for 12V halogen lamps are 11V-12.5V. Voltage range for LED lamps are 9V-17V.

Lamp: 80CRI CREE INTEGRATED LED

Hardware: Hexagonal crew fix to part.

Gasket: A thick rubber gasket

Warranty: Limited lifetime Warranty.

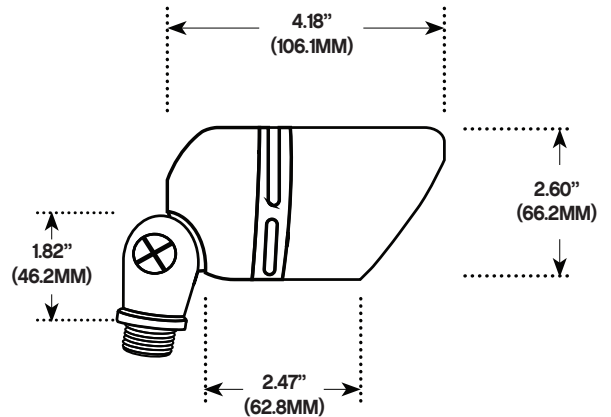

ORDERING INFORMATION

Sample Part Number: GRD562-3K-AB

MOUNT	LIGHT ENGINE	SERIES	CONTROL OPTION	VOLTAGE	CCT	FINISH	BEAM °
GR - In-ground	D - 7W, 450lm Dedicated CREE LED	562 - Brass Lilac	blank - Dimming	blank - 12V AC	27 - 2700K	56 - Antique Bronze	35 -35° 60 -60°
TR - Surface, Tree Mounting					3K - 3000K		
					5K - 5000K	; A - Gun Metal	
						A6 - Mid Night Black	

ACCESSORIES

In-Ground ABS Stake



Surface / Tree Mounting

